

Stehende Einzylinder- Dampfmaschine mit Muschelschiebersteuerung und Kreuzkopfführung

Bohrung: 17 mm
Hub: 28 mm
ØSchwungrad 90 mm

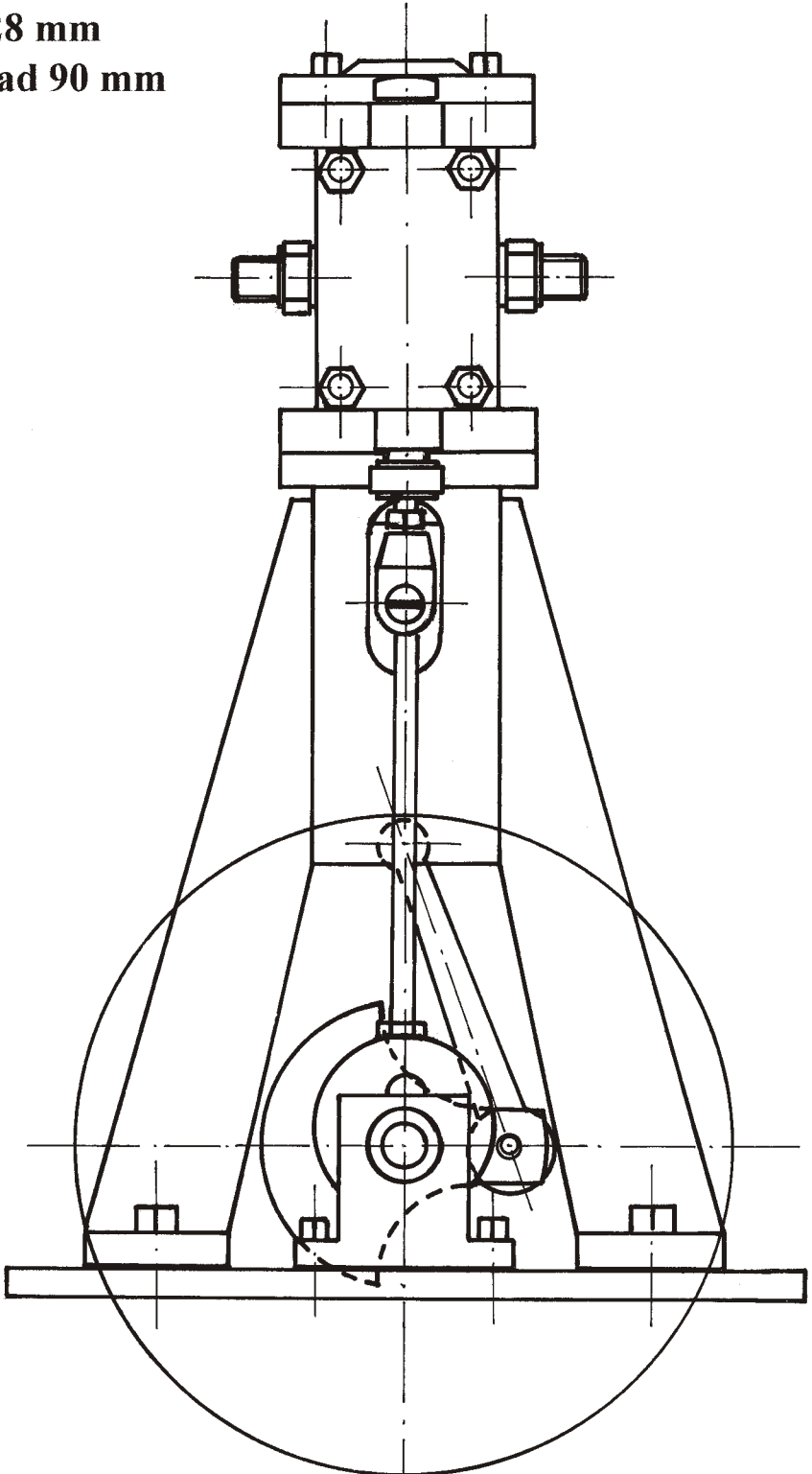

Draufsicht

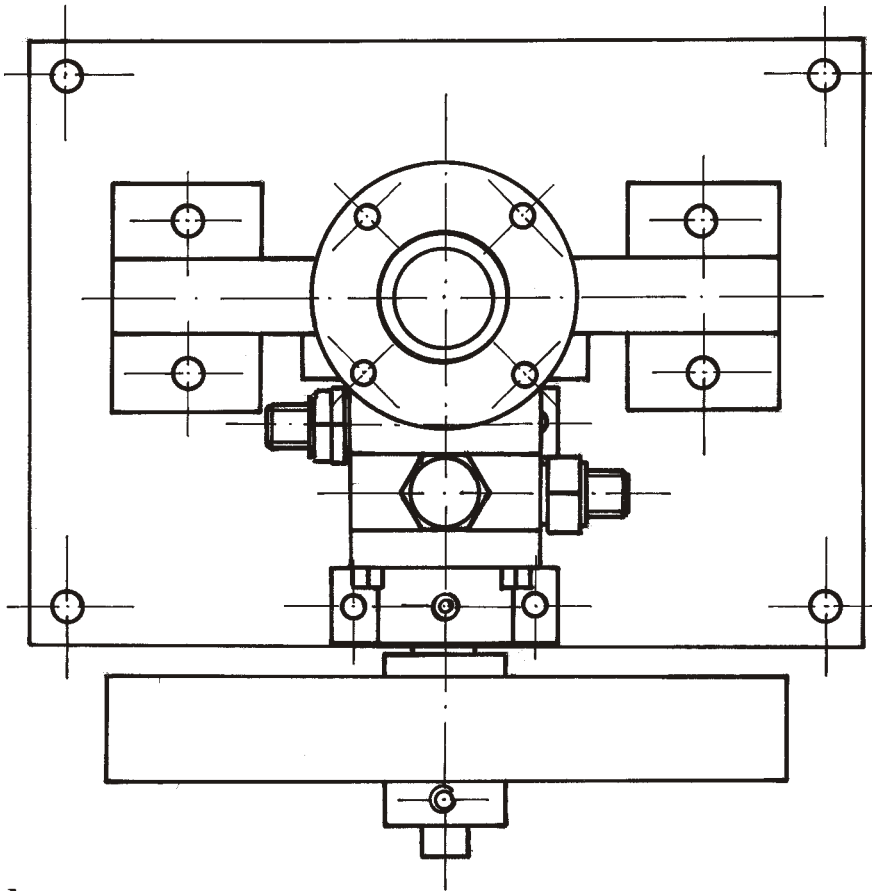

Grundplatte

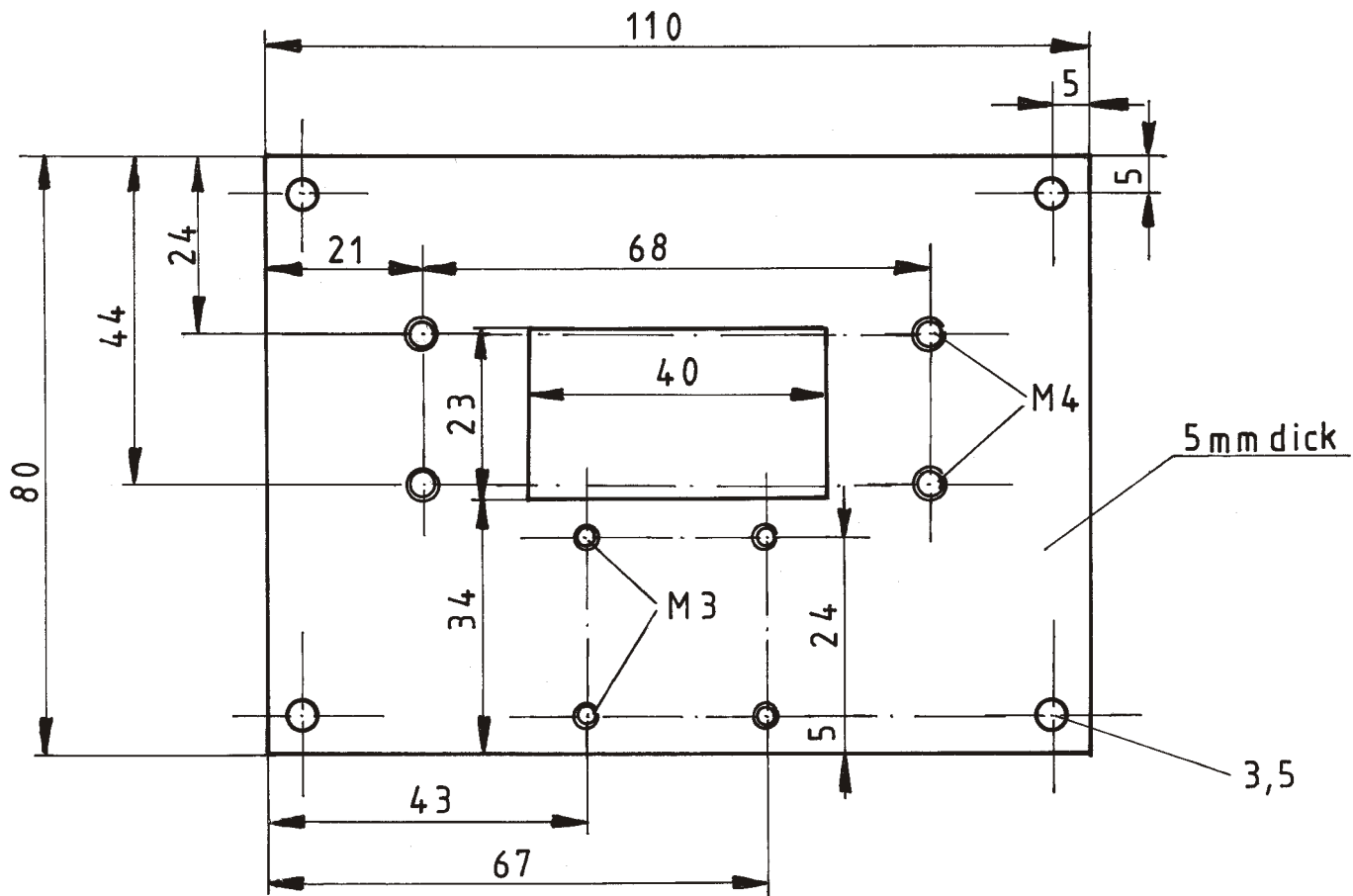

Hauptständer

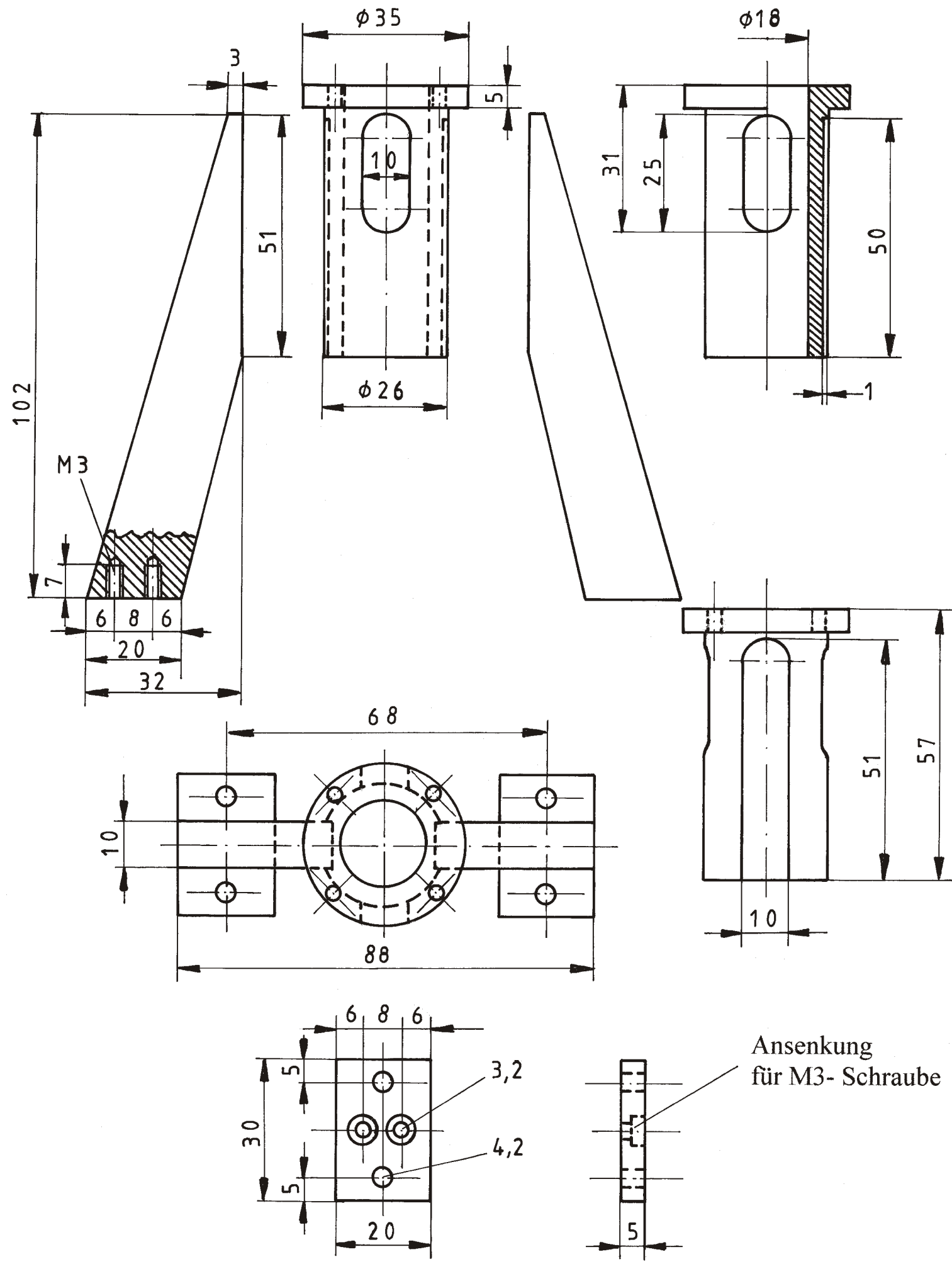

Zylinder

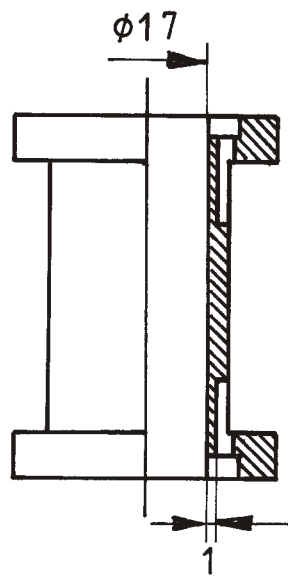
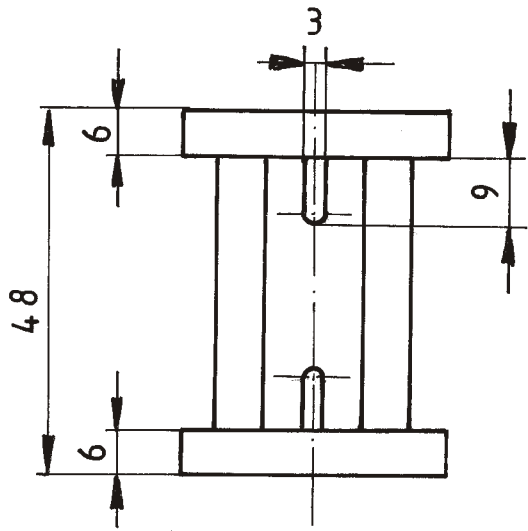

Schieberplatte

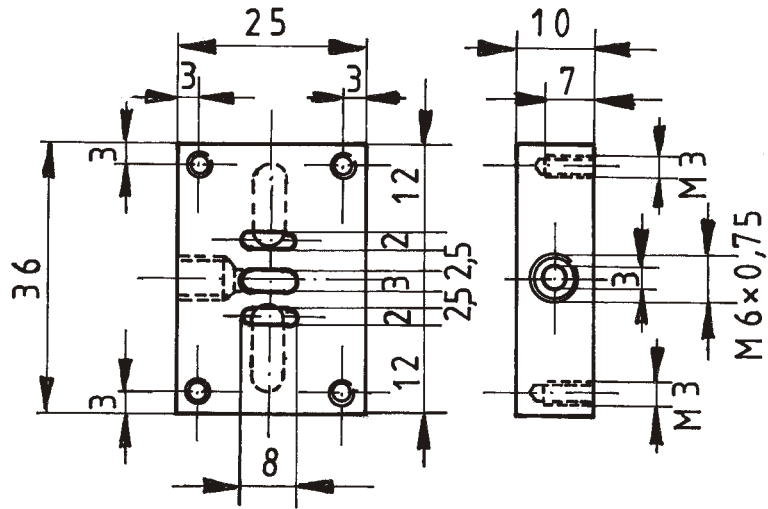
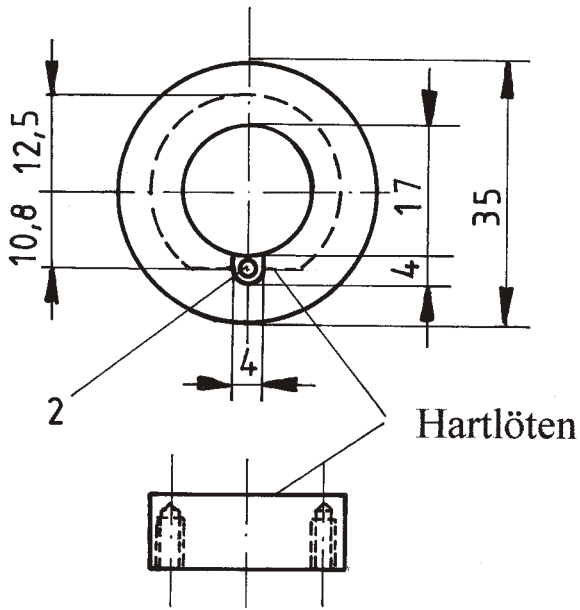

Anschlußstück

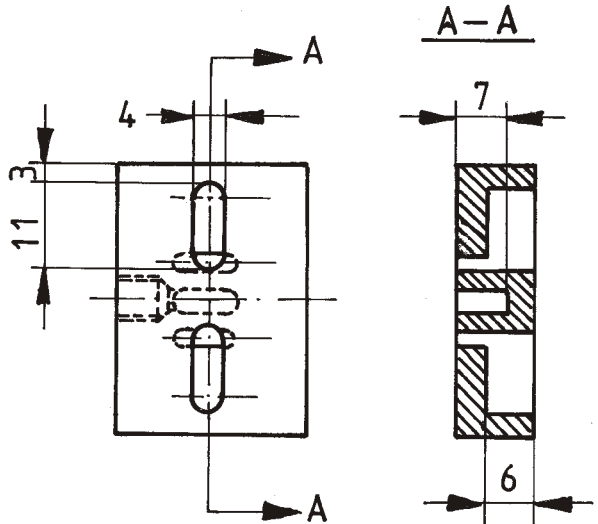
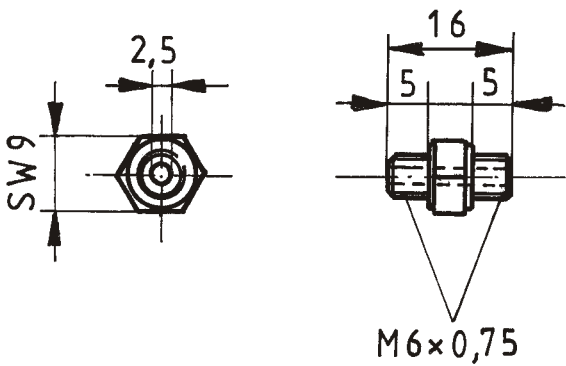

Oberer Zylinderdeckel

Unterer Zylinderdeckel

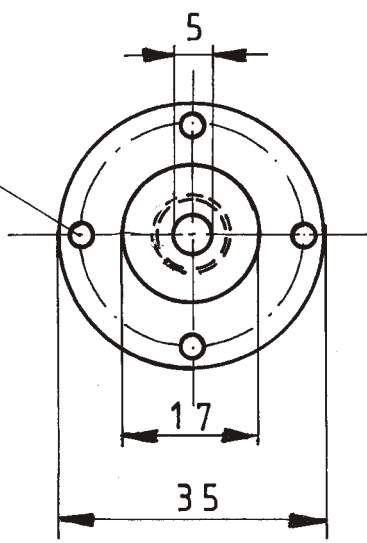
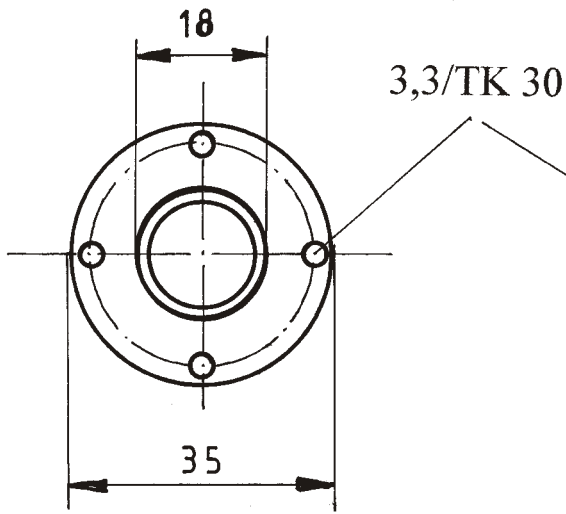
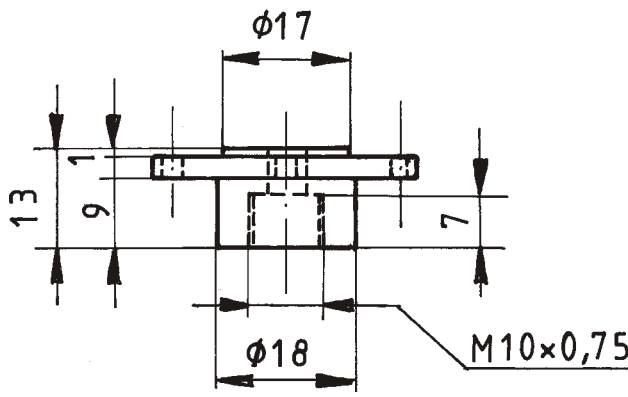
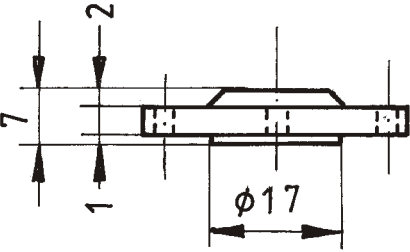

Kreuzkopf

Stopfbuchse

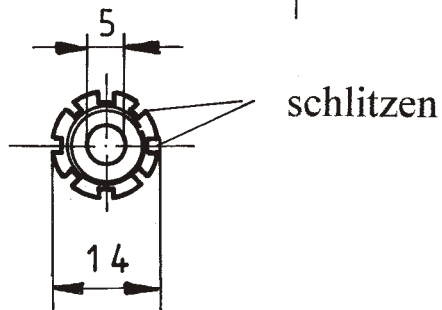
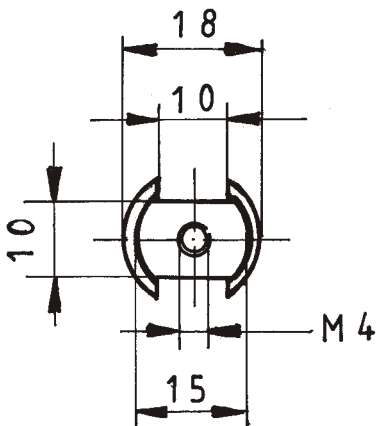
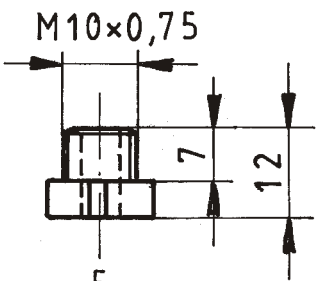
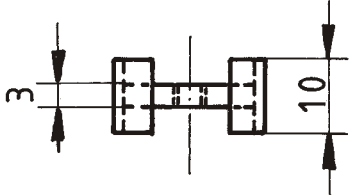

Kolben

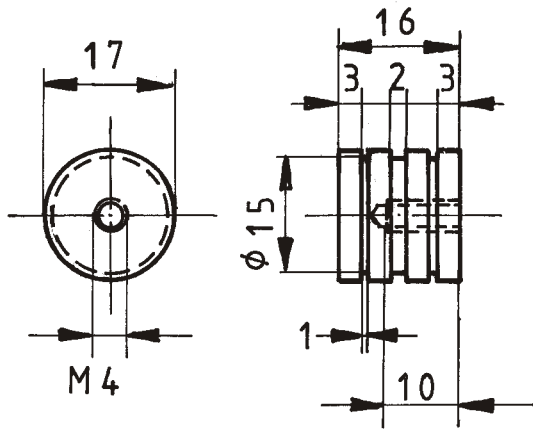

Kolbenstange

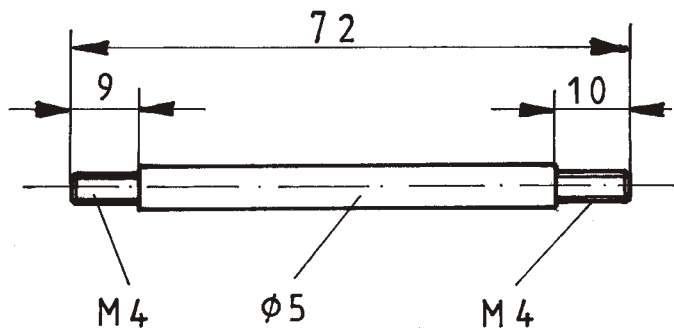

Gabelkopf

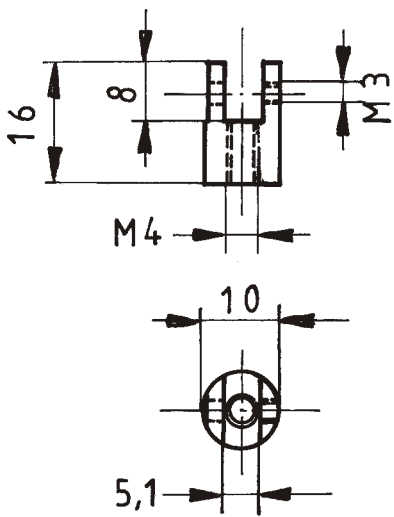

Fläche anfeilen

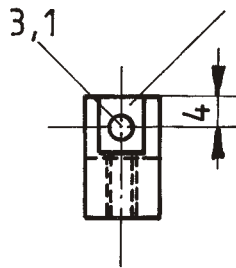

Schieberkastendeckel

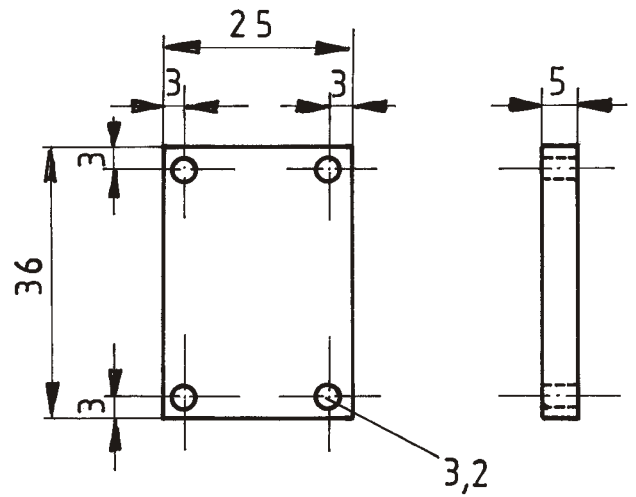

Schieberkasten

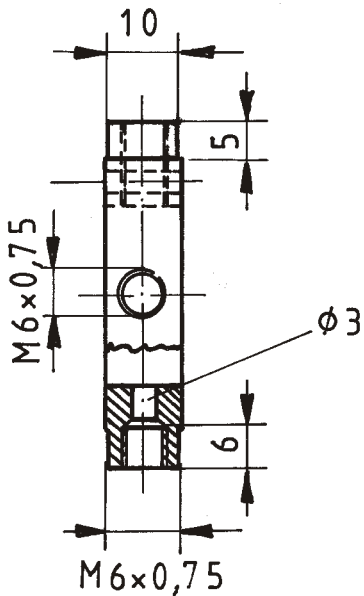
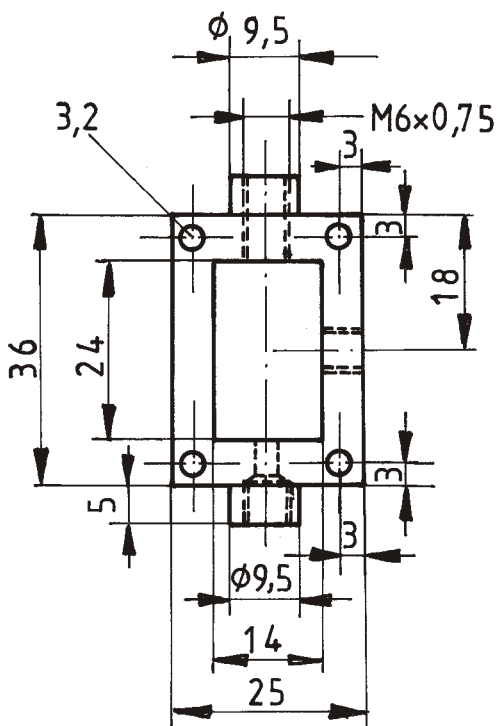

Schieberstangenführung

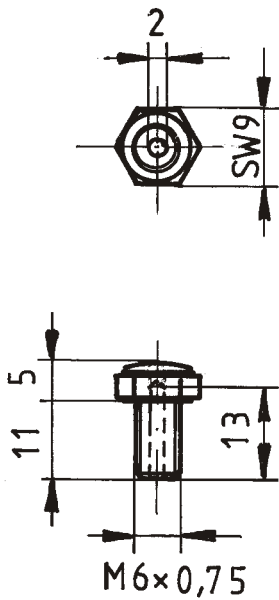

Stopfbuchse Schieberstange

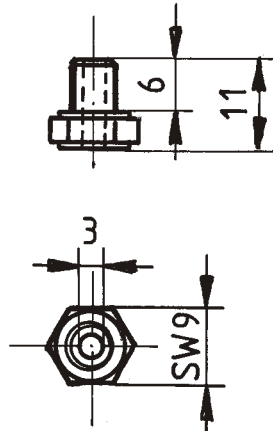

Schieberstange

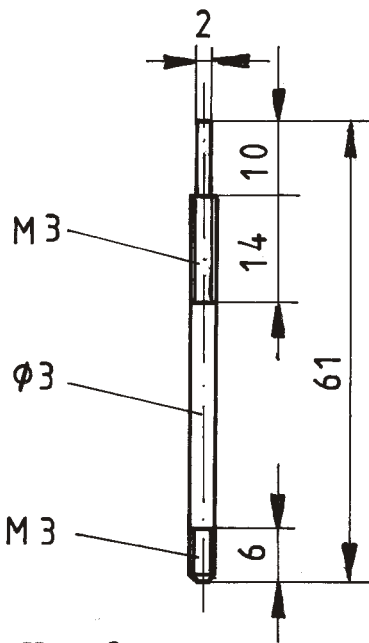

Mitnehmer

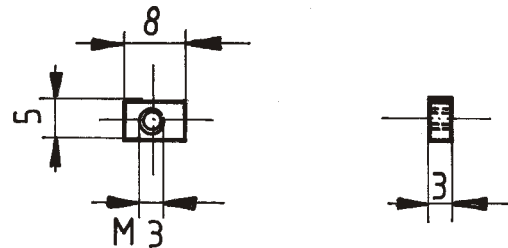

Schieber

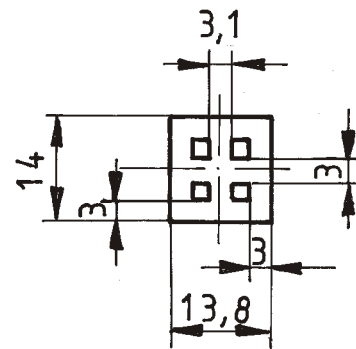

Gabelkopf

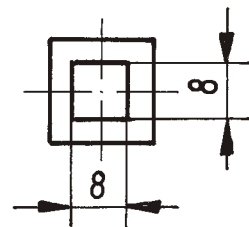
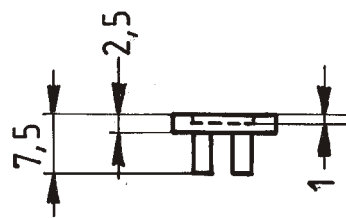
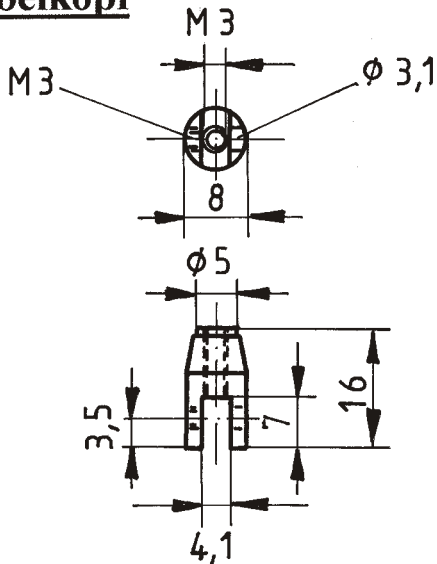

Excenter

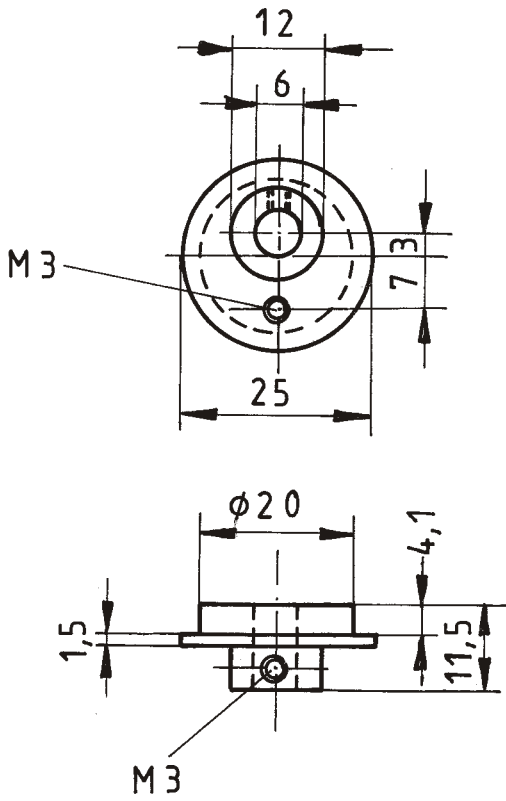

Excenterstange

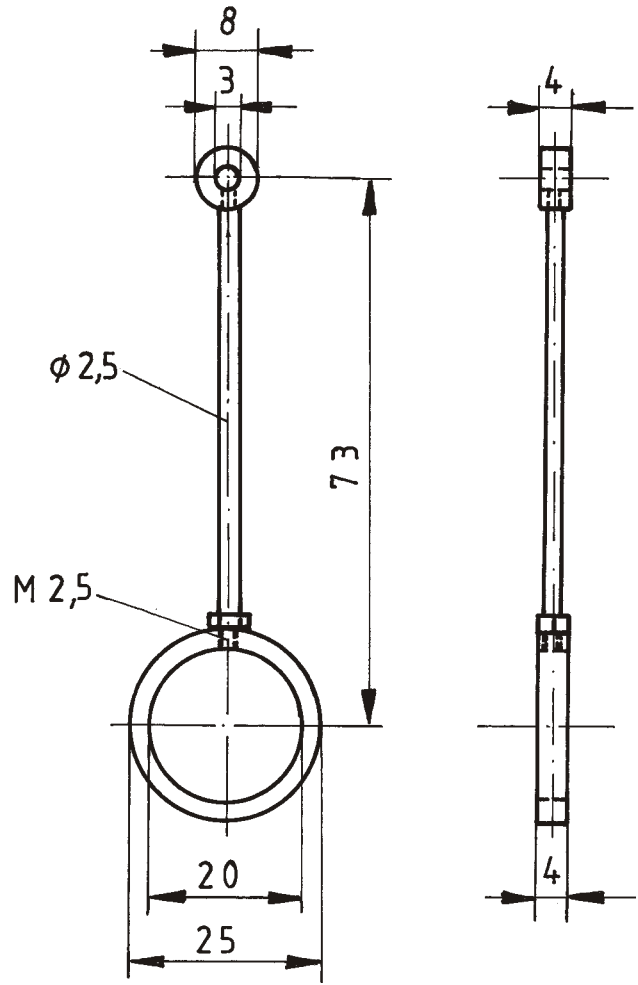

Deckscheibe

1,5 mm dick

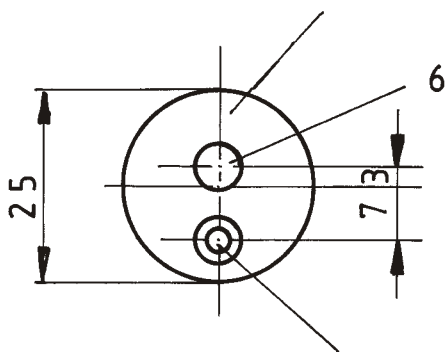

Bohren und Ansenken für M3

Pleuel

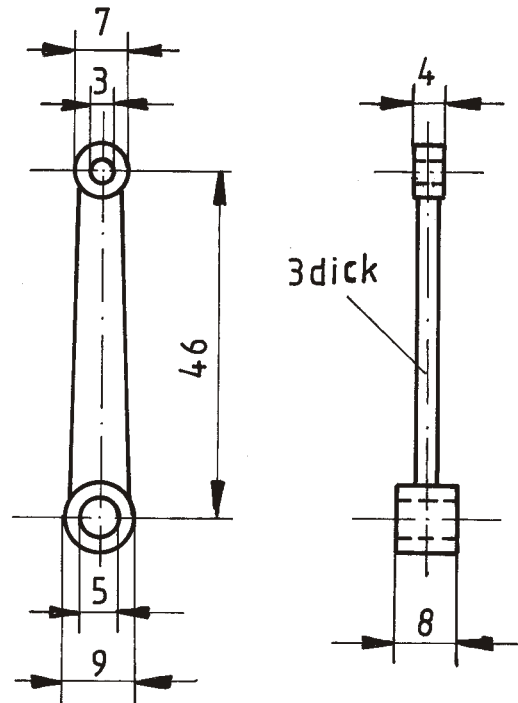

3 dick

Lagerzapfen

Pleuel

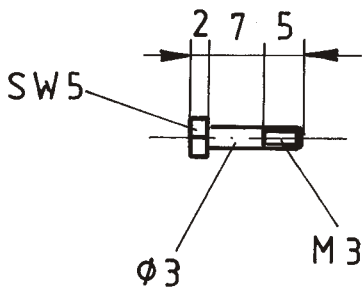

Lagerzapfen Excenterstange

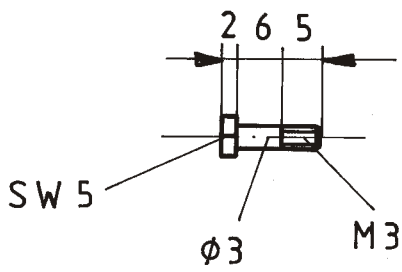

Kurbelzapfen

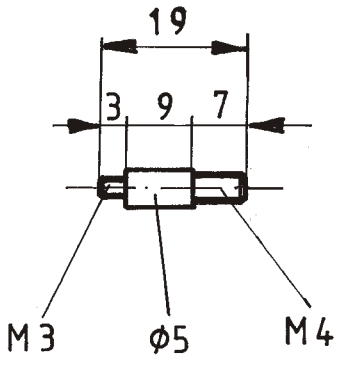

Kurbelwange

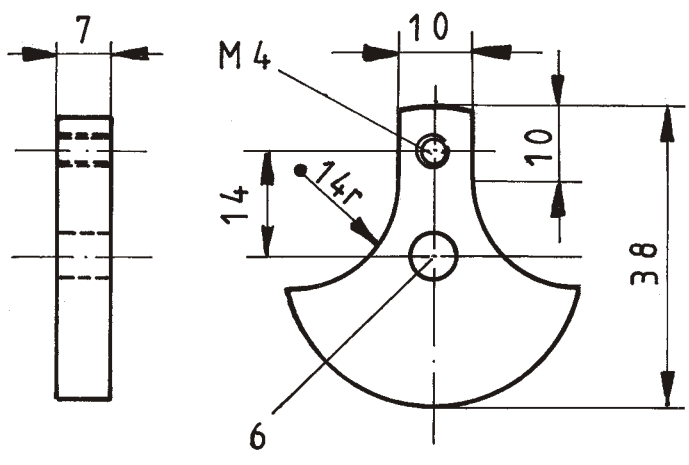

Kurbelwelle

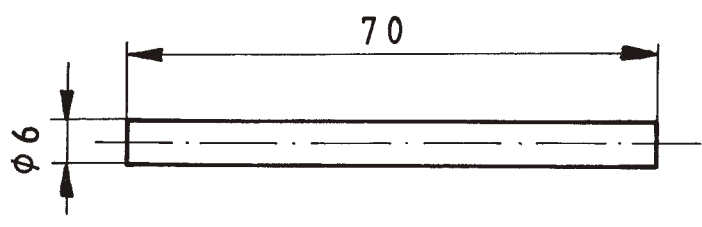

Lagerbock

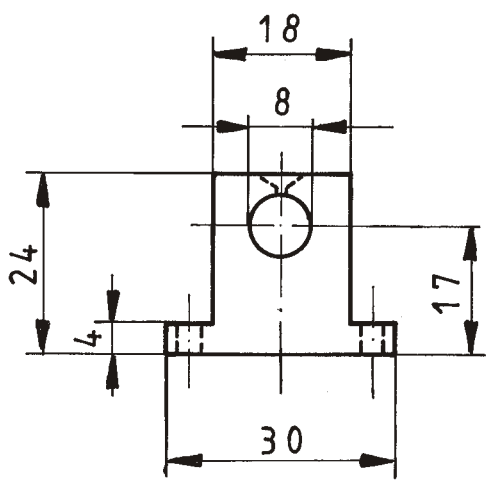

Lagerbuchse

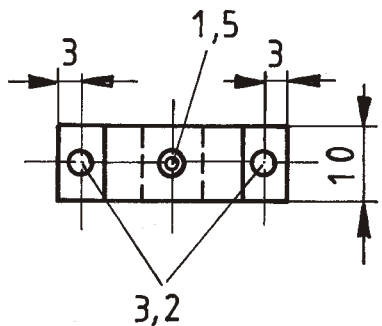
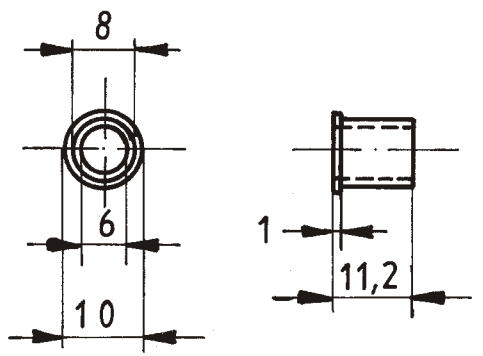

Zylinderummantelung

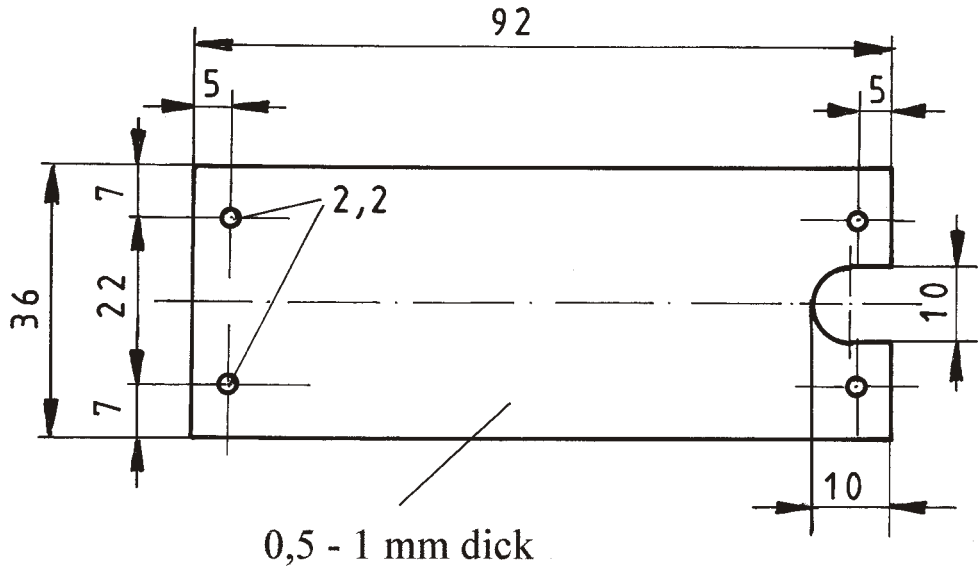

Bohrungen seitlich an
der Schieberplatte Zylinder

